

RECYCLER MRX-R™

MRX-R™
Modular Banknote Recycler Family

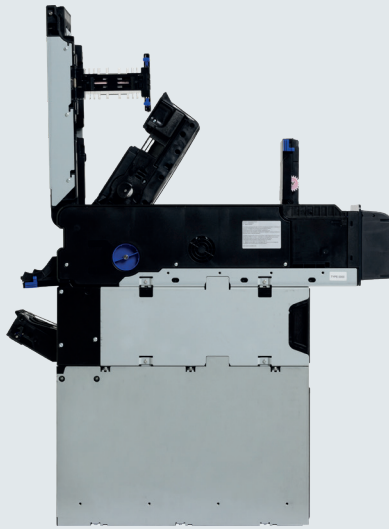

MOST ADVANCED TECHNOLOGY

- ◆ Contact Image Sensor Technology (CIS)
- ◆ Coin Protection Feature

LOW-COST OF OWNERSHIP

- ◆ Field replaceable modules
- ◆ Extended product durability (min. 2.500.000 million cycles)
- ◆ Heavy-duty design and durable lifecycle

HIGHEST FORM OF RELIABILITY

- ◆ More efficient transport path that leads to higher reliability
- ◆ Transport path for the bank notes is more compact

MORE COMPACT AND LIGHTER DESIGN

- ◆ More compact design to give more space in the application
- ◆ Easy access because of the modular construction

SERVICE FRIENDLY CONSTRUCTION

- ◆ Compatible with existing modules

INNOVATIVE TECHNOLOGY DESIGNED FOR RETAIL

- ◆ Selfcheckout
- ◆ ATM
- ◆ Safes

REDUCE DOWNTIME AND LOWER COST OF OWNERSHIP IN YOUR RETAIL BUSINESS WITH THE NEW MRX-R™

The MRX-R by JCM Global sets a new benchmark in cash handling technology specialised in the retail sector. Built for extreme durability, proven reliability, and effortless serviceability, it delivers a long lifecycle with reduced downtime and lower total cost of ownership for the retail market. Designed for demanding retail environments, the MRX-R ensures fast, secure, and seamless banknote recycling — empowering your operation with consistent performance.

GENERAL SPECIFICATION

ACCEPTANCE RATE

- 98% or greater

FEED

- Bulk note up to 30 notes

PROCESS SPEED

- 2 notes per second (in and out)

BANKNOTE SIZE RECYCLER

- Long side: 110 - 170mm
- Short side: 60 - 82mm

BANKNOTE INSERTION DIRECTION

- 4 ways

BARCODE TICKET

- 2 ways (face up)

RECYCLER CAPACITY

- up to 8 drums, each drum up to 60 notes

DIMENSIONS IN MM

- 467 (H) x 440 (D) x 165 (W) (standard configuration*)

WEIGHT

- Approx. 22kg (standard configuration*)

SUPPLY VOLTAGE

- DC +24V (± 10%)

COMM. INTERFACE

- RS232C/USB for host communication
- USB for maintenance

* Head Unit, one Recycler Drum and one Cashbox

Contact Image Sensor (CIS)

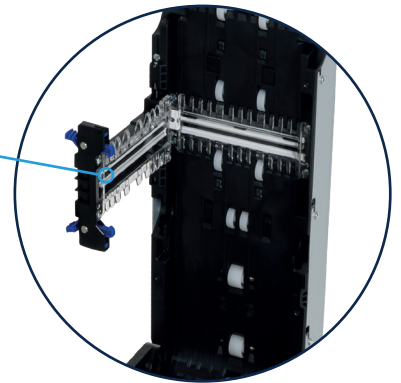

New Gearbox Module

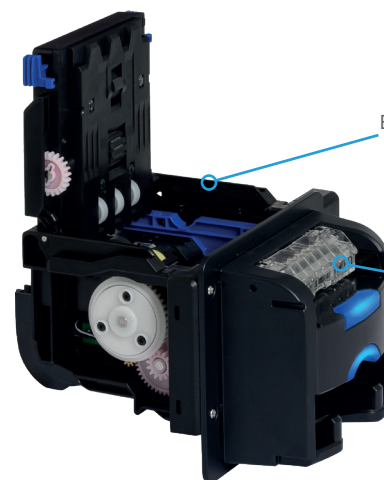

Easy Access Modules (Service-friendly)

Coin Protection Feature



JCM Europe GmbH
Muendelheimer Weg 60
D-40472 Dusseldorf,
Germany
Tel: +49 211 530645-0

Japan Cash Machine Co., Ltd
Osaka:
8F, Parks South Square,
2-11-18, Nambanaka,
Naniwa-ku, Osaka 556-0011
Japan
Tel:+81-6-6643-8400

Japan Cash Machine Co., Ltd
Tokyo:
15th Floor, Mita Bellju Building,
5-36-7 Shiba, Minato-ku,
Tokyo 108-0014, Japan
Tel: +81-3-6812-8220

JCM American Corporation
925 Pilot Road
Las Vegas, NV 89119, USA
Tel: +01 800-683-7248
(800# for USA, Canada & Mexico)
Tel: +01 702-651-0000

FOLLOW US ON



JCM Global, JCM Global logo, and other marks used herein are trademarks and registered trademarks of Japan Cash Machine Co., Ltd. and JCM American Corporation. Additional marks are registered trademarks of their respective owners. JCM Global reserves the right to change product specifications without notice.

Find out more at
www.jcmglobal.de